

User manual

DUKA One Pro 25 S

Ventilation Unit with Heat Recovery

Indhold

Information og Sikkerhed	3
Garantibestemmelser	4
Indhold i kassen	4
Teknisk Information	5
Opbygning	5
Teknisk Data	6
Dimensioner	7
Montage	8
El tilslutning	12
Sammenkobling af enheder	13
Indstillinger	14
Betjening	15
Vedligehold	17
Fejl og problemløsning	19

Information and Safety

Transport and Storage

The unit must be protected from shocks, impacts, and weather conditions during transport.

Store the unit in its original packaging in a dry and ventilated room at temperatures between 5°C and 40°C.

The storage room must not contain aggressive or chemical vapors or gases.

Do not expose the stored unit to pressure or other loads.

Usage

The unit should only be used for room ventilation. Do not connect a dryer or similar equipment.

Its primary function is to ensure basic ventilation in the home.

The unit should only be turned off if required by authorities or for safety reasons (e.g., fire).

The unit cannot be used as a heating source or a dehumidifier.

Keep explosive and/or highly flammable dust, vapors, and liquids away from the unit.

The air entering the unit must not contain chemical vapors, coarse dust, soot, oil, adhesives, fibrous materials, pathogens, or other harmful substances.

Do not block the unit's air channel while it is in operation.

Do not direct airflow from the unit towards open flames.

Before Installation

Read and understand the user manual before installing and using the unit.

Check the product for damage to the fan, core, front cover, electronic components, and exterior screen. Any foreign objects inside can damage the unit.

Keep the quick guide for easy access to the latest manual via the QR code.

If ownership of the unit changes, pass on the quick guide.

Installation

The unit is designed for installation in an exterior wall.

Unpack the unit carefully.

Follow all applicable building, electrical, and technical regulations when installing the unit.

Ensure all electrical safety rules are followed. More information is available at www.sik.dk.

If any wiring is damaged, it must be replaced according to applicable regulations.

The unit must not be subjected to pressure, as deformation can cause motor blockage and excessive noise.

Operation

Disconnect power before installation, servicing, maintenance, or repair.

(Exception: Filter replacement, see maintenance section.)

Do not operate the unit outside the specified temperature range.

Do not operate or service the unit with wet hands or bare feet to prevent electric shock.

Do not allow children to operate the unit. Children must be supervised to ensure they do not play with it.

Unauthorized modifications or improper use of the unit are not permitted.

The unit should not be operated by individuals with reduced physical, sensory, or mental capabilities unless supervised or instructed.

Cleaning

Do not wash the unit with water.

Protect electrical components from water.

Warranty Conditions

24-month warranty from the date of purchase under the Danish Purchase Act.

An additional 12-month warranty is provided if transport, storage, use, installation, operation, maintenance, and warranty conditions are followed.

To maintain the warranty, filters must be replaced at least once per year with original DUKA Ventilation filters.

(Keep receipts as proof.)

The Warranty Does NOT Cover:

Routine maintenance.

Setup, configuration, and dismantling of the unit.

The Warranty is VOID if:

Transport, storage, usage, installation, operation, maintenance, and warranty guidelines are not followed.

The unit is used or installed in wet rooms or unsuitable environments.

The unit has been turned off without an official requirement to block external airflow.

Mold damage is present.

The unit has visible physical damage.

The unit is connected to an incorrect power supply.

Damage occurs due to power surges or voltage fluctuations.

Non-original filters are used.

Unauthorized repairs or modifications have been made.

The failure is due to force majeure (e.g., lightning strikes, fire, floods, earthquakes).

Proof of purchase cannot be provided.

The warranty period has expired.

For warranty claims, submit an online complaint form at: www.dukaventilation.dk/reklamation.

DUKA Ventilation is not responsible for warranty obligations performed without prior agreement.

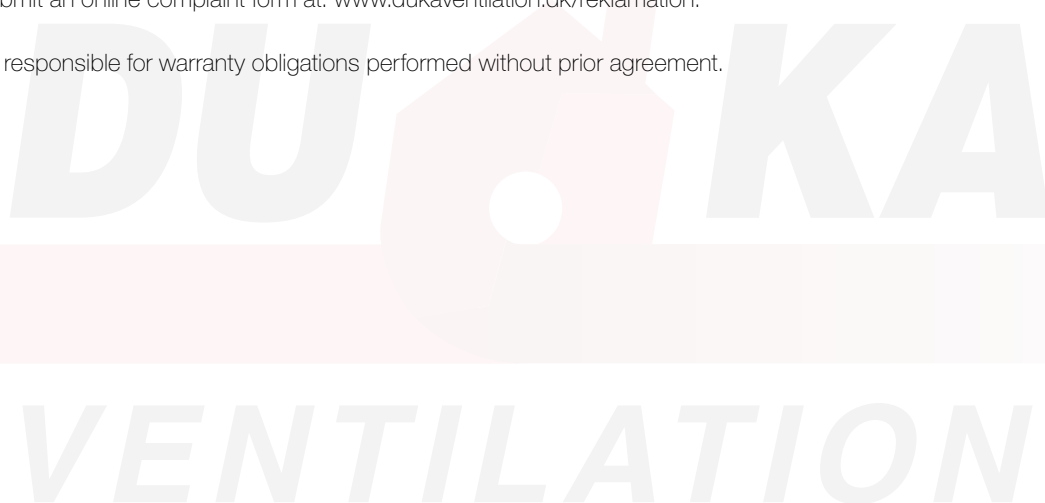

Contents of the Box

- Front cover and electronic component
- Sound absorber
- 500mm pipe
- Installation template
- Storm shield and drip plate
- Ceramic heat exchanger
- Mounting kit
- Remote control

Technical Information

Designed for indoor use at 1°C to 40°C, with up to 80% relative humidity.
Air supply and exhaust range: -15°C to 40°C.
Must operate continuously.
Electrical Classification
Class II
IP Rating: IP 24

Structure

The unit consists of:

- Front cover: Removable for servicing.
- Electronic component: Contains controls and wiring.
- Ceramic heat exchanger: Maximizes energy recovery.
- Sound absorber: Reduces motor noise and external sound.
- Storm shield: Protects against wind and rain.
- Drip plate: Prevents condensation from running down exterior walls.
- Low-energy motor: Handles both air supply and exhaust.

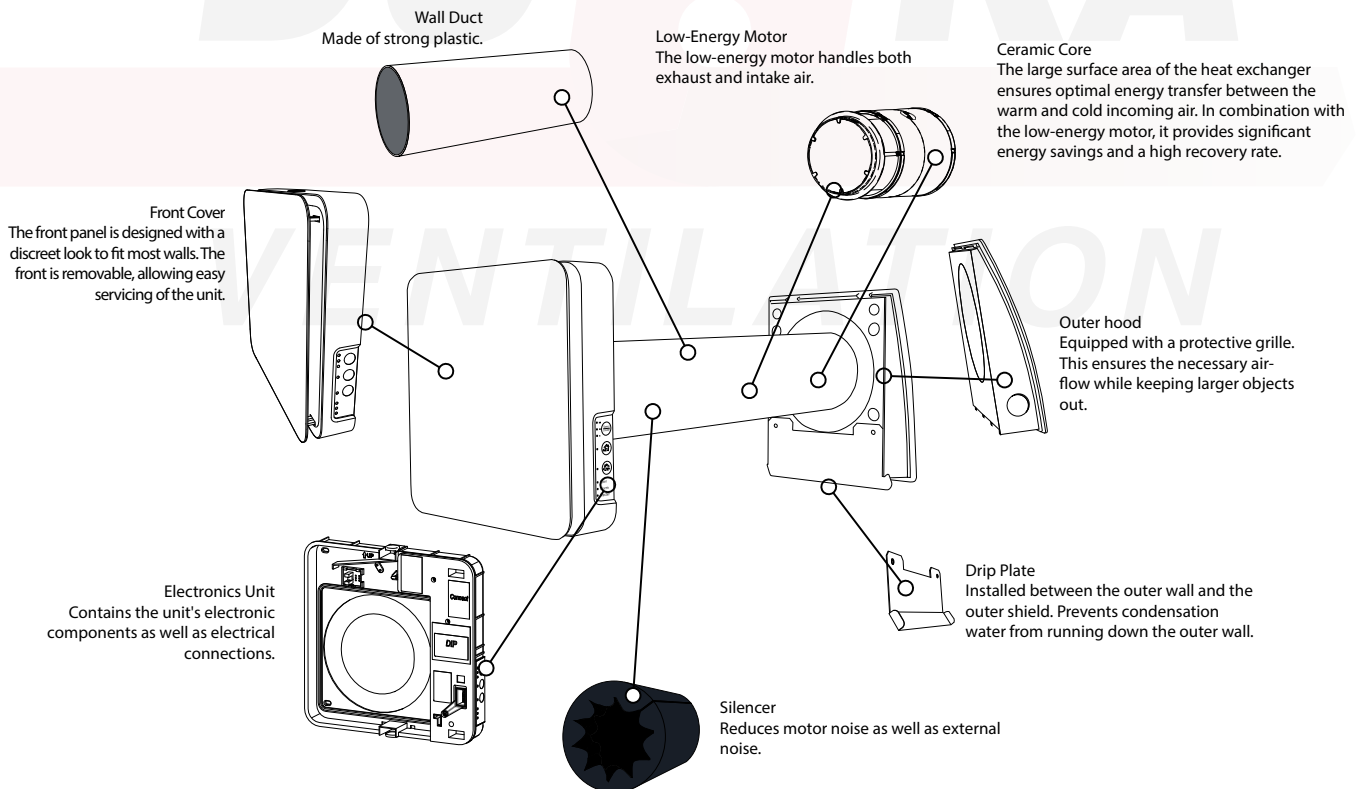

Technical Data

	DUKA ONE PRO 25		
Speed	1	2	3
Voltage [V/Hz]	100-240V ~50/60 Hz		
Power [W]	1,40	2,00	3,00
Current [A]	0,03	0,04	0,05
Air flow in ventilation mode [m ³ /h]	8	16	25
Air flow in heat recovery [m ³ /h]	4	8	12,5
Transported air temperature [°C]	-15 ... +40		
Filter	G3		
Sound pressure level at 1 m [dBA]*	30	33	42
Sound pressure level at 3 m [dBA]*	28	30	37
Outdoor sound pressure attenuation [dBA]	40		
Regeneration efficiency [%]	≤ 81		

* Functional measurements conducted by DUKA Ventilation

DUKA

VENTILATION

Dimensions

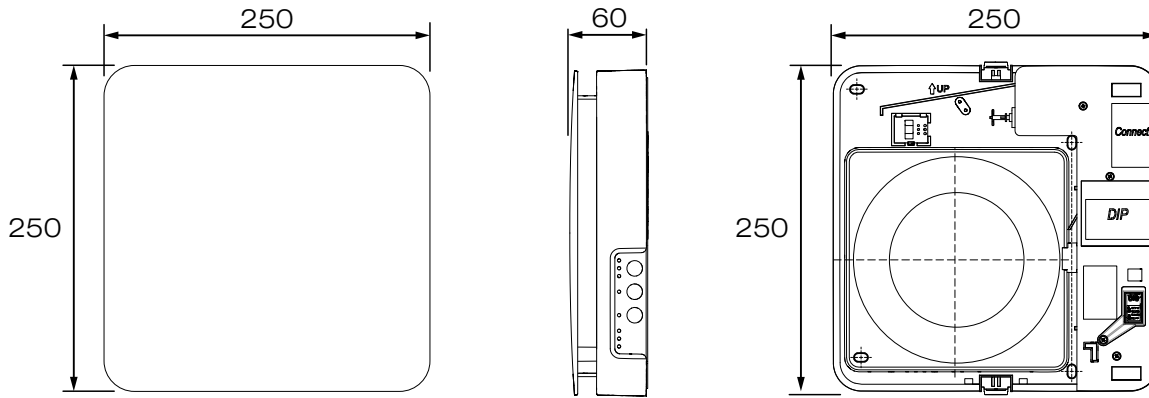
Indoor part

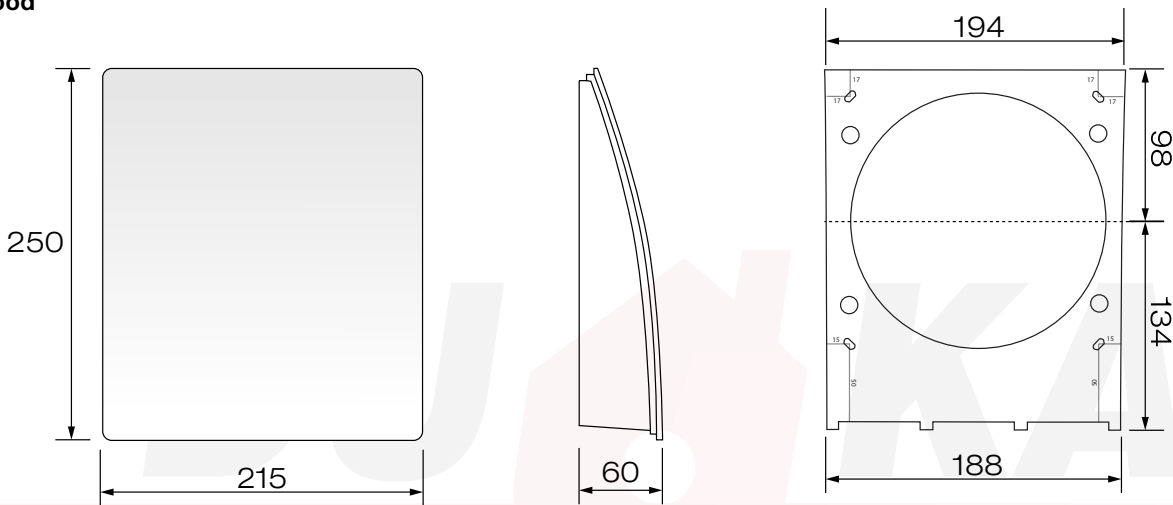

Outer Hood



Minimum wall thickness and placement

If the wall thickness below the minimum requirement is it recommended to purchase a DUKA One distance piece
Placement of the ceramic core according to wall thickness.

	DUKA One Pro 25 S Wi-Fi
Hole diameter (for installation)	105-125 mm
Ceramic core length	165 mm
Smallest possible wall thickness* 270 mm	165 mm

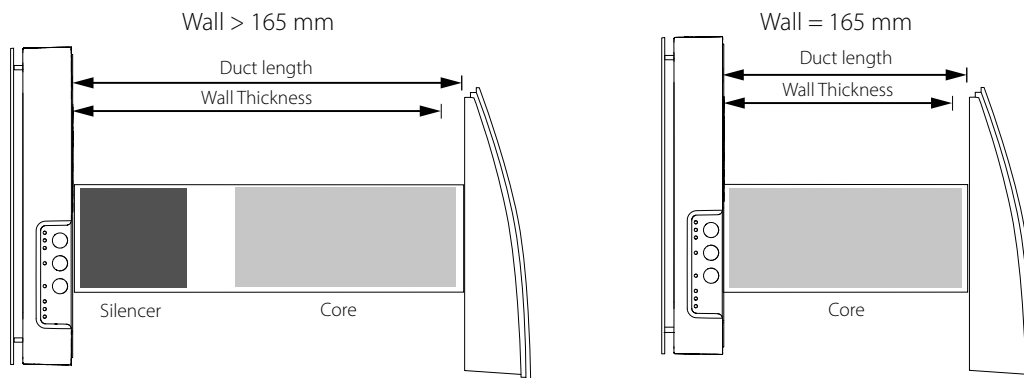

Installation

1 - Determine the location and drill the hole through the wall.

Before placing the unit, minimum distances to the side wall, ceiling and any windows must be taken into account.

The minimum distances are showed on the drawing.

Also remember to take into account the power supply for the unit when choosing a location.

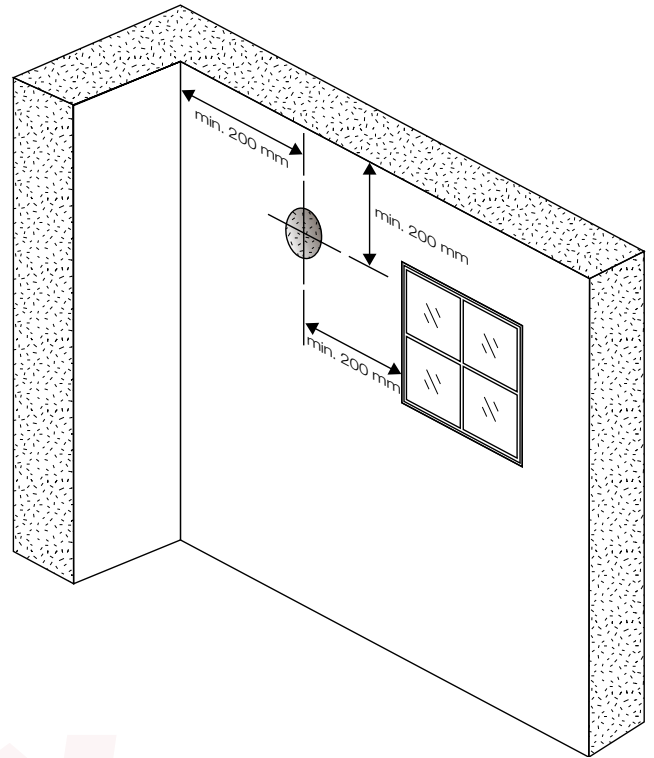

2 - Place the wall pipe and adjust the length according to wall thickness

It is important that the pipe is installed with a minimum gradient of 3 mm towards the outer hood to ensure possible condensation water is leads towards the outer hood and not the units electrical components.

For an easy installation use the supplied Styrofoam wedges.

The tube must have maximum put out of 3 mm on the inside and 5 mm on the outside.

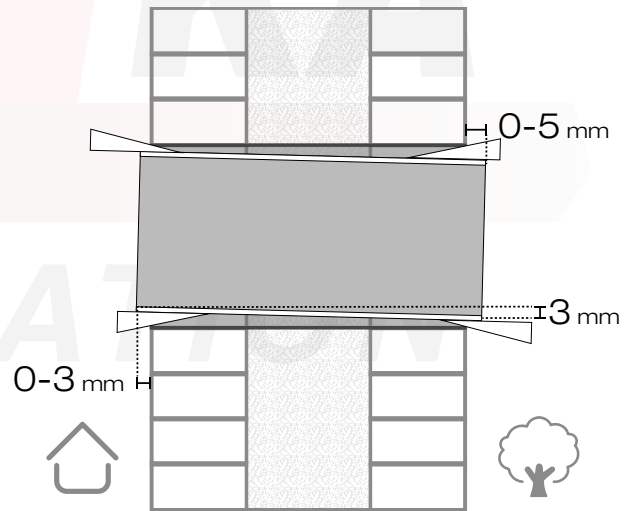

3 - Use the supplied template for easy marking and drilling of necessary installation holes og for possible hidden cabling.

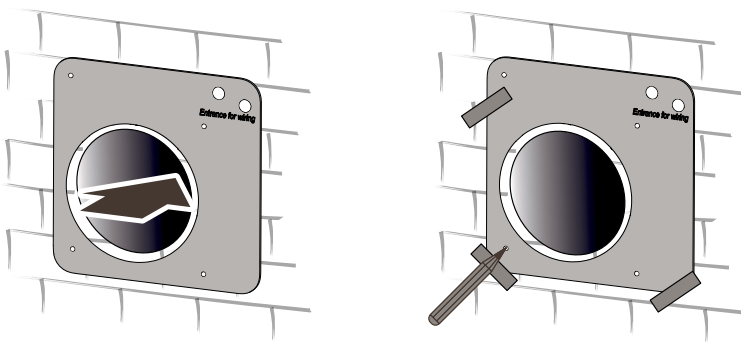

8

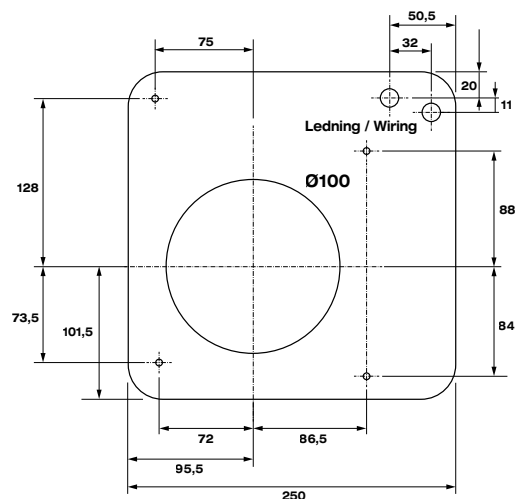

4 - Disassemble the front cover by pressing on the two buttons

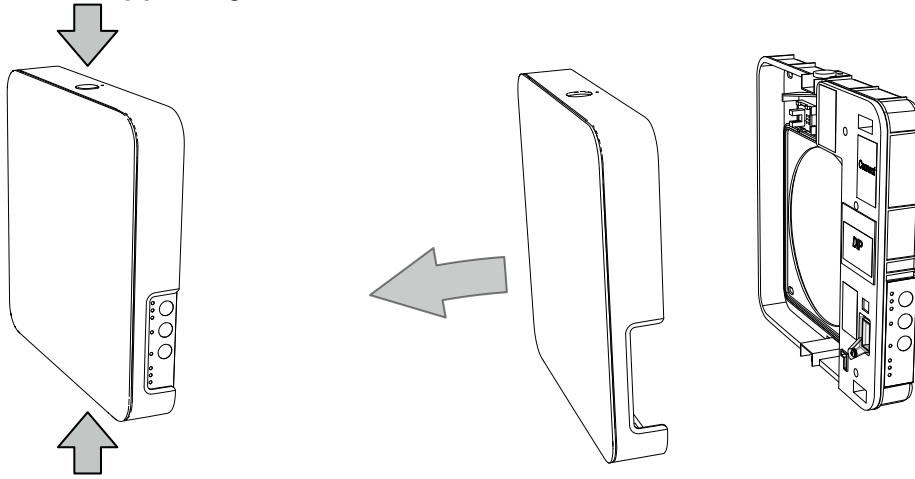

5 - Install the electronic part with the supplied screws and disassemble the right cover plate.

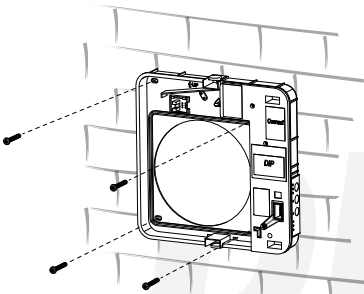

6 - Connect the wires according to the wiring diagram and place them as shown below. Remember to place the wires in the clamps.

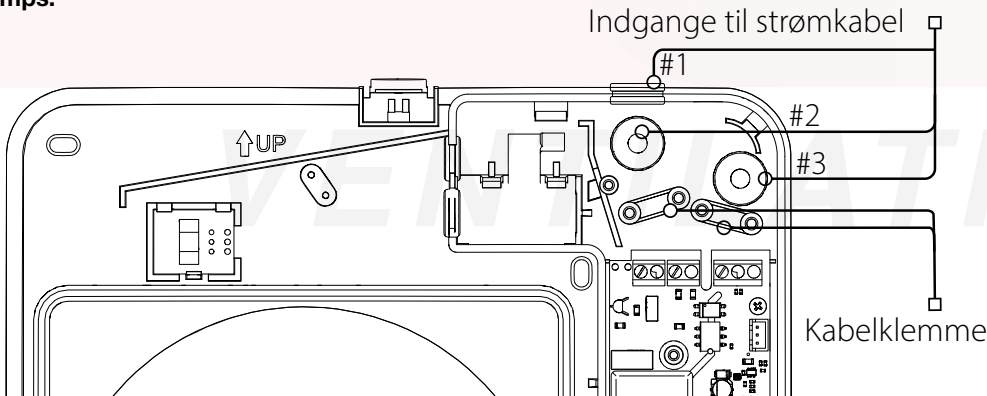

If input #1 on the top of the unit is used, the provided template in the center of the mounting template should be used to mark the notch. Drill out the notch so that the cover can be easily mounted and removed from the unit.

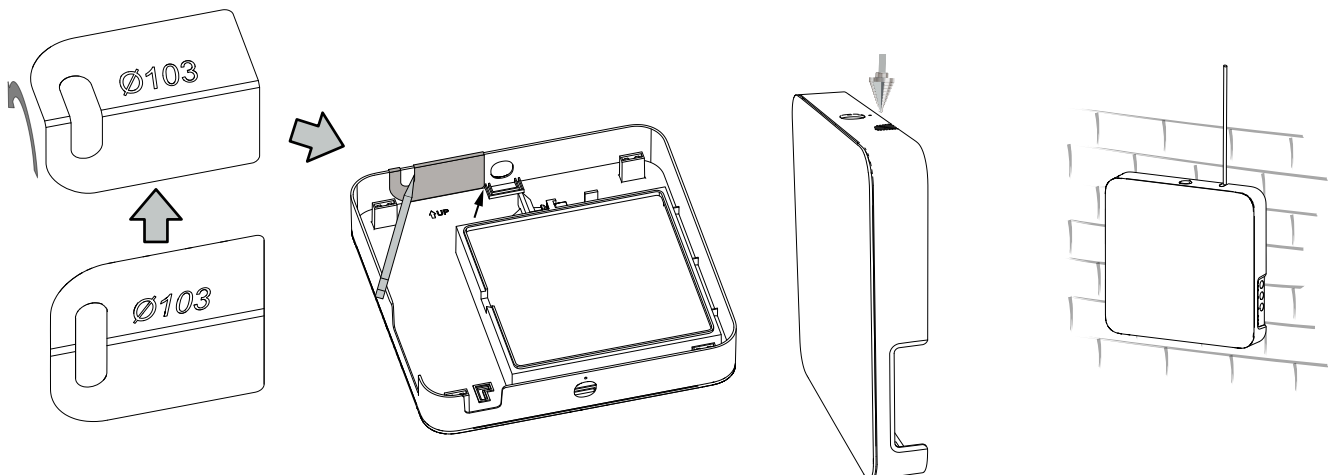

7 - After the unit has been connected to the power supply assemble the cover plate again.

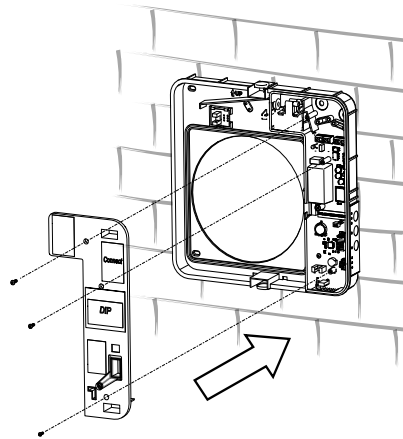

8 - Install the core

Install the core and connect it to the electronic part with the green plug.

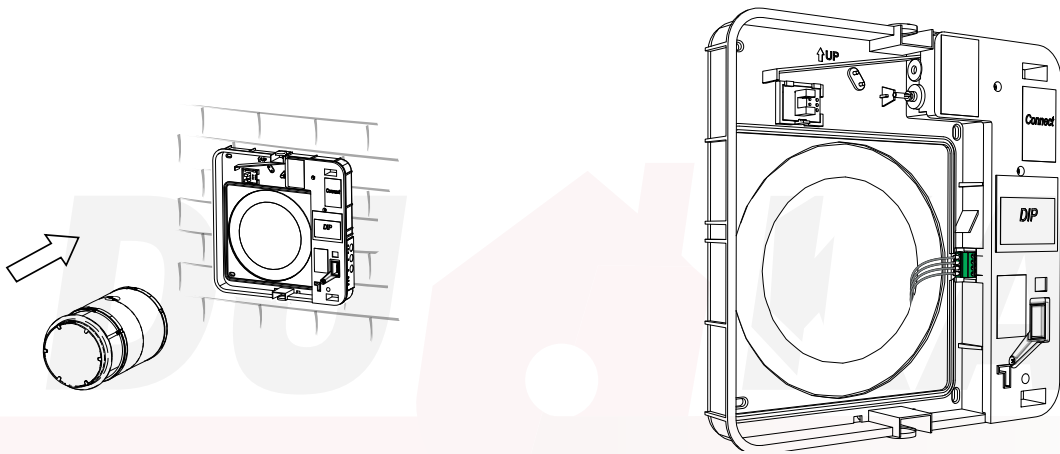

9 - Install the silencer

Place the silencer in the pipe and roll it to make sure it fits the diameter of the pipe. Cut it in order to make it fit to the wall thickness with the core in the pipe. The silencer is installed loosely so that it can be removed for maintenance.



10 - Install the front cover

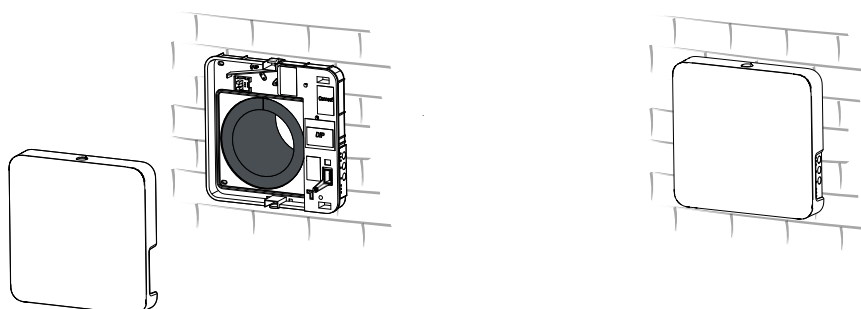

11 - Remove the front cover on the outer hood before installing it.

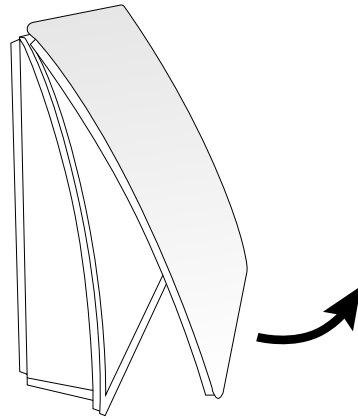

12 - Install the outer hood and the drop plate.

The supplied drop plate is installed on the back side of the outer hood as shown on the image to the right. The drop plate ensures that condensation water is lead away from the wall.

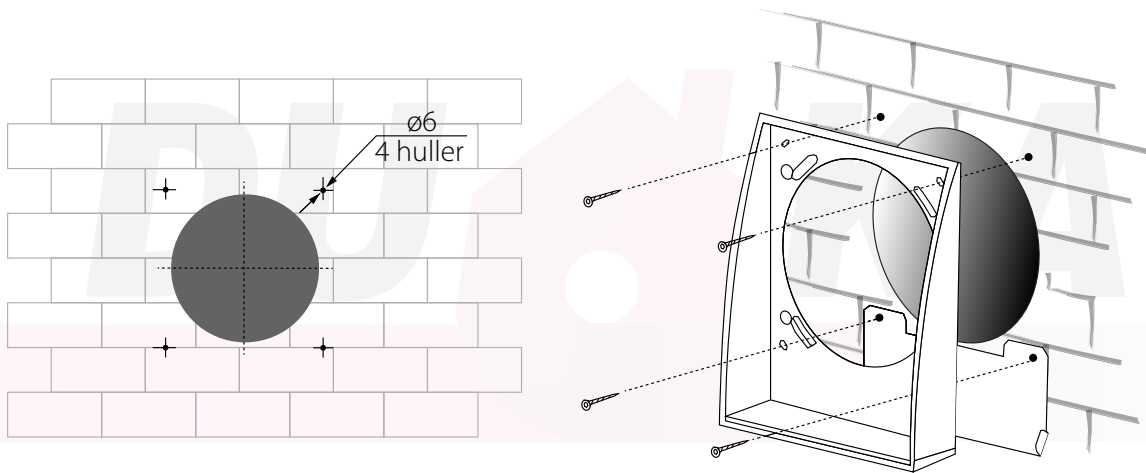

13 - Install the front cover on the outer hood.

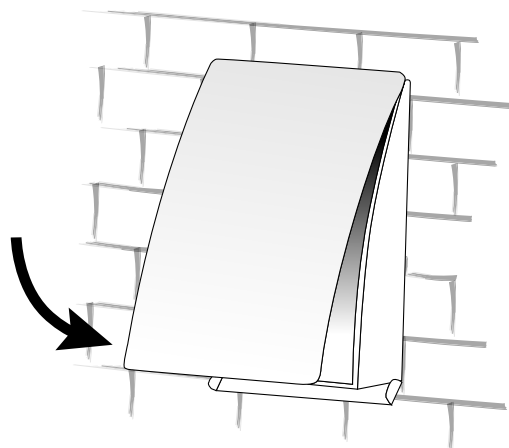

Connection to power mains



ALL CONNECTIONS TO POWER MAINS MUST BE DONE BY A CERTIFIED ELECTRICIAN. CONNECTION THAT HAVE BEEN MODIFIED OR ARE ILLEGAL WILL DISCONTINUE THE PRODUCT WARRANTY.
NOTE: AS A PRIVATE PERSON IT IS ILLEGAL TO CARRY OUT A PERMANENT ELECTRICAL INSTALLATION.
LEARN MORE AT THE DANISH SAFETY GOVERNMENT WWW.SIK.DK

The unit must be connected to a single-phase AC 100-230 v / 50-60 Hz power supply.

The unit must be connected to the power mains via the terminal on the circuit board in accordance with the electrical diagram below.

It is possible to connect an external NO switch, like as a sensor, to the device. When the circuit is closed, the unit will start operation on level III and when the circuit is broken again, the unit will return to the previous speed setting.

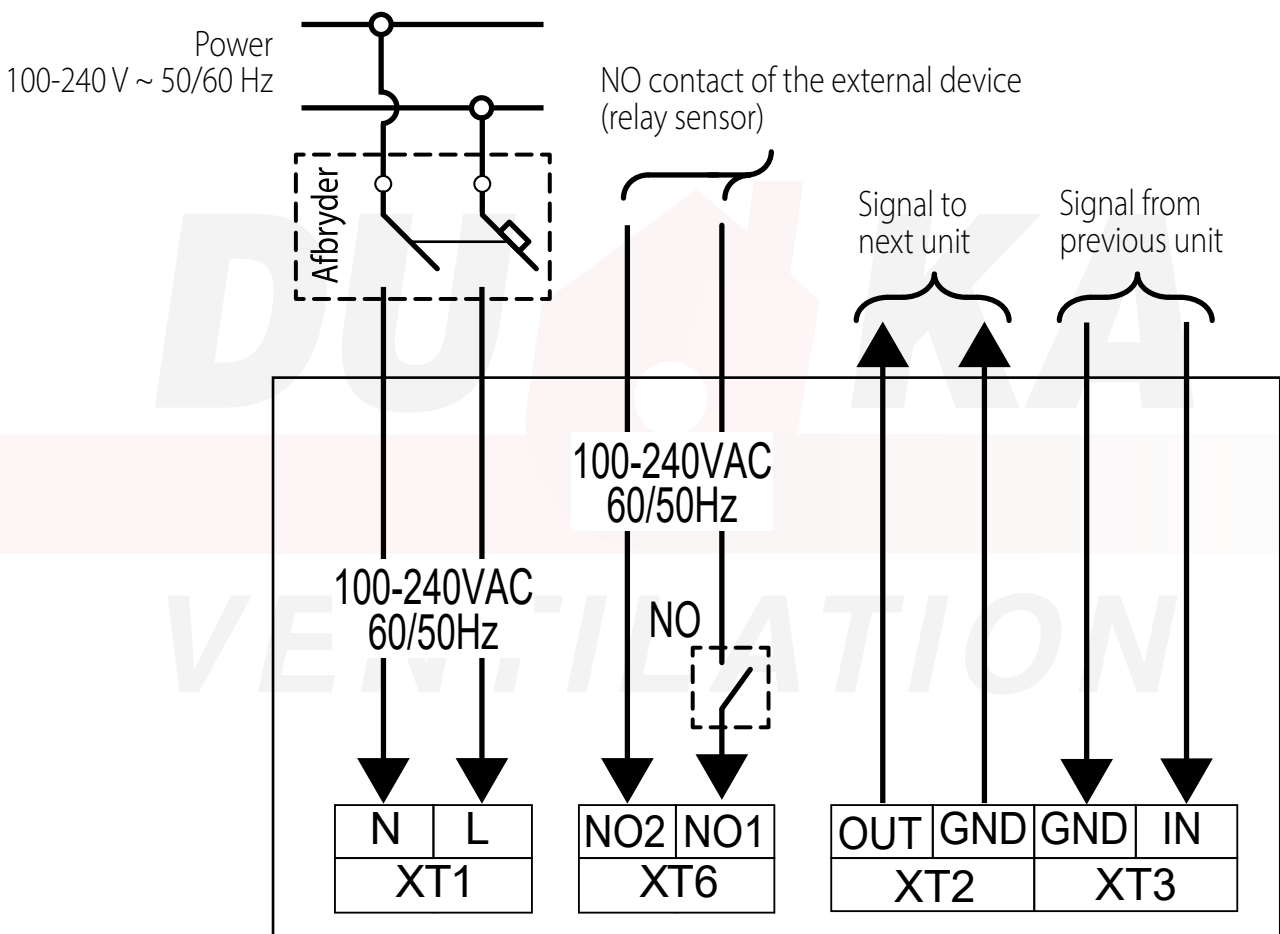

Connecting Multiple Units

When multiple units are linked in a master/slave setup, they will operate in sync, ensuring balanced ventilation throughout the home.

It is recommended to use a 0.25 mm² cable for the connection, and the cable length should not exceed 200 meters between units.

It is not possible to have multiple master units within the same connection. The units must be wired according to the electrical diagrams below.

For linked units, only the master unit can be controlled via the remote control or control panel. Slave units will respond only to signals from the master and will ignore other inputs.

When linking multiple units in a master/slave configuration, the master unit's XT2 terminal must be connected to the slave unit's XT3 terminal. This pattern continues for all subsequent units in the series. It is only possible to have one master unit in the setup.

The master unit is defined by the fact that it does not have a connection to an XT3 terminal.

Wiring Diagram for Connecting Multiple Units

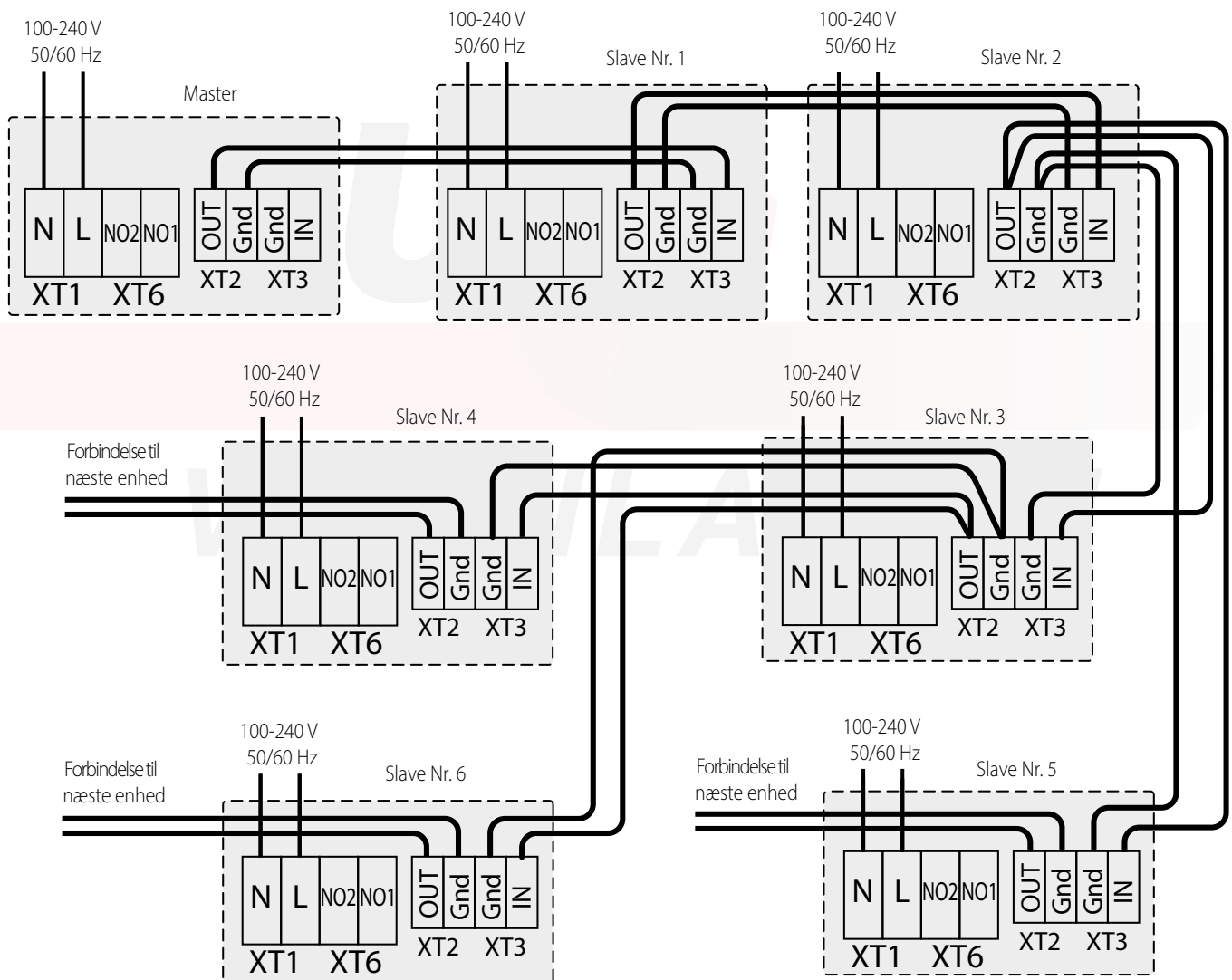

Settings

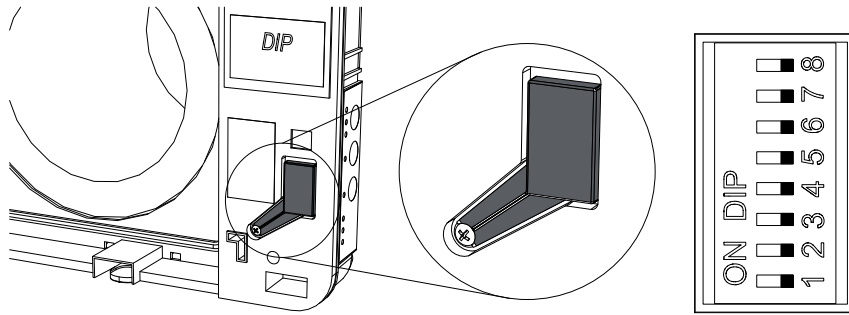

Before starting the DUKA One unit, the operating settings must be adjusted to suit individual needs. This is done via the DIP switches located under the DIP switch cover.

Standby settings

	↑	ON - The unit cannot be turned off and will operating on level 1 in standby mode
	↓	OFF - the unit can be turned off and put in standby mode.

If the unit is set to OFF, it will not be possible to turn off the unit on the display or the remote. It will only be possible to select operating level I, II and III.

Unit direction settings

	↻	ON - The unit will start operation with extraction and will extract air in ventilation mode.
	↻	OFF - The unit will start operation with extraction and will extract air in ventilation mode.

Is several units installed, it is recommended to install the unit in pairs. Select "ON" on half the units and "OFF" on the other halves. This setting will ensure balanced ventilation.

Humidity sensor setting

	5	Off - 0%		5	40%		5	50%		5	60%		5	70%		5	80%
	4			4			4			4			4				
	3			3			3			3			3				

When the humidity level exceeds the selected humidity level, the unit will switch to forced operation at level III. When the humidity level again is below the set level, the unit will return to the previous operating setting.



Delay time sensor

	7	OFF - 0 MIN		7	5 min		7	15 min		7	30 min
	6			6			6			6	

The delay timer is used together with the humidity sensor. When the humidity sensor is deactivated the delay time sensor will be activated for the chosen time interval. When the delay time is deactivated the unit will return to previous operating setting.

	∞	ON - Restore factory settings (wait for the bilb and move it back)
	∞	OFF - Standard position.

Operation of the unit via buttons on the inner part

FUNCTION	
	<p>Level setting: Level I – II – III or standby</p> <p>I : If the indicator shines the unit is operating at level I. If the indicator flashes night mode activated.</p> <p>I and II : If indicator I and II shines the unit is operating at level II.</p> <p>I, II and III : If indicator I, II and III shines the unit is operating at level III.</p> <p>If all three indicators are flashing, it may be due to the following: Party timer is activated, the built-in humidity sensor is activated or one of the connected external sensors are activated. If several units are connected in a master/slave network, is the speed level setting controlled by the master.</p>
<p>Heat recovery function</p> 	<p>The unit is operating 70 seconds in air supply mode and thereafter 70 seconds in air extraction mode.</p>
<p>Ventilation function</p> 	<p>The unit is operating in the chosen speed level in either supply or extraction mode. The air flow direction is dependent on DIP-switch settings. For more information please see settings section with subsection "Unit direction settings".</p>
<p>Filter alarm</p>	<p>The filter alarm will shine every 90 days, when it is time to inspect the filters. The filters must either be cleaned or changed. See more under the section "Maintenance".</p> <p>If several units are connected will the indicator on the master unit shine constantly, while the slave units which needs to be inspected will have a flashing light indicator.</p> <p>The filter alarm can be reset by following the guide under "Maintenance" section or by holding down the heat recovery button on the side of the unit, until you hear a short biib.</p>
<p>Alarm indicator</p>	<p>The indicator will shine when an error occurs on the unit.</p> <p>Are the units connected to each other will all units stop. The alarm indicator will be flashing on the defect unit and shine on the other units.</p>
<p>Master indicator</p>	<p>Only the master unit will shine, when several units are connected. Slave units will not have a light in their indicator. If the slave units indicator is flashing, it means that there is no connection to the master unit.</p>

VENTILATION

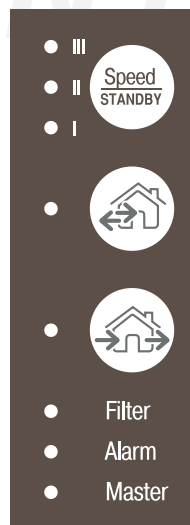







— Change speed / Standby

— Heat recovery mode

— Ventilation mode

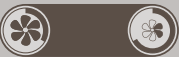
Operation of the unit with remote control

FUNCTION	
	Turn on or standby Will either turn on the unit or put it on standby unless this function have been deactivated via the DIP-switches, see more under the "Settings" section.
	Air speed level Level III - II - I
	The unit is operating 70 seconds in air supply mode and thereafter 70 seconds in air extraction mode.
	The unit is operating in the chosen speed level in either supply or extraction mode. The air flow direction is dependent on DIP-switch settings. For more information please see settings section with subsection "Unit direction settings".
Timer function 	Party mode: Activates speed level setting III for 4 hours.
	Night mode: Activates speed level setting I for 8 hours.
When the timer expires will the unit return to previous operating setting. Deactivate the function by pressing any button.	

VENTILATION

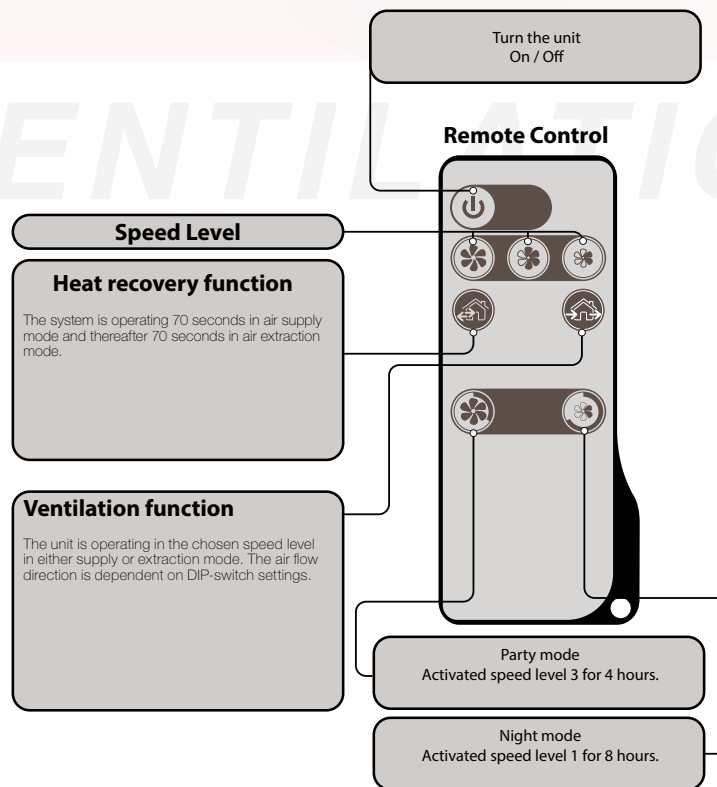

Maintenance



THE POWER MUST THEN BE SWITCHED OFF BEFORE CARRYING OUT ANY FURTHER MAINTENANCE TASKS ON THE UNIT.

A DUKA One unit must be inspected and maintained at least every three months. There may be conditions under which it is necessary to check the unit more often, e.g. in a dusty, dirty or humid environment. During maintenance the core must be removed. The ceramic core and silencer must be cleaned and the filters must either be cleaned or replaced.

1 - Remove the front cover

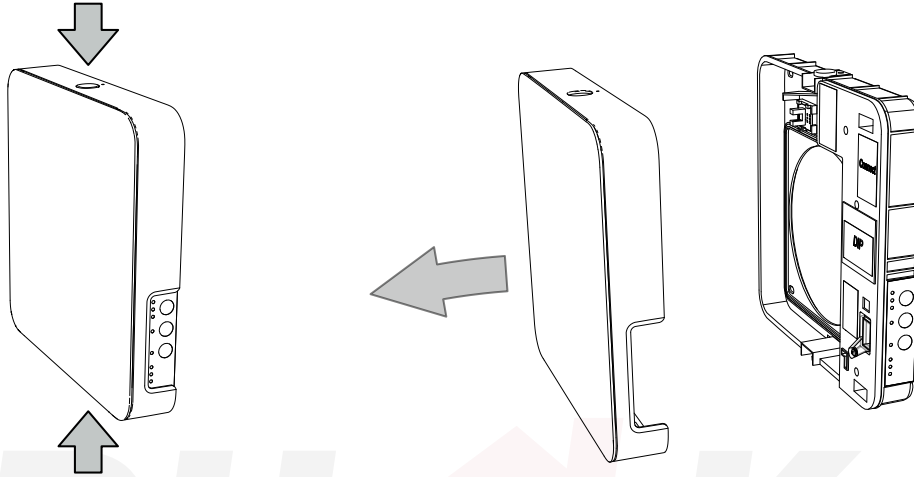

2 - Detach cable plug

Be careful when removing the cable plug from the electronic part. Use a flat screwdriver to loosen the cable plug from the socket. Do not pull on the wires.

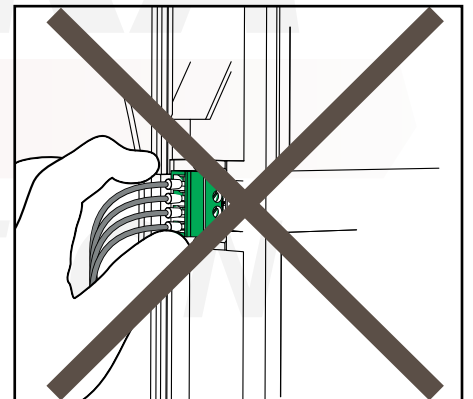
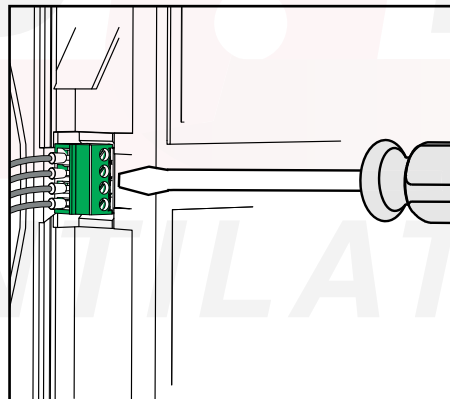
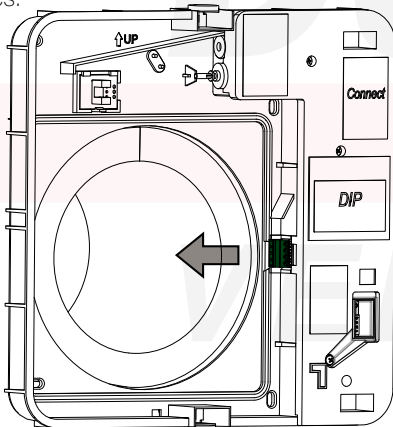

3 - Remove silencer, motor and core from the tube.

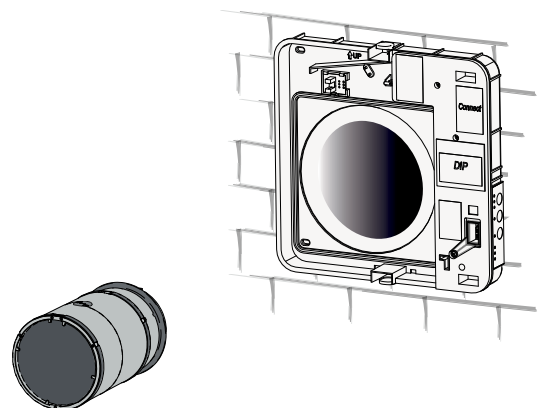
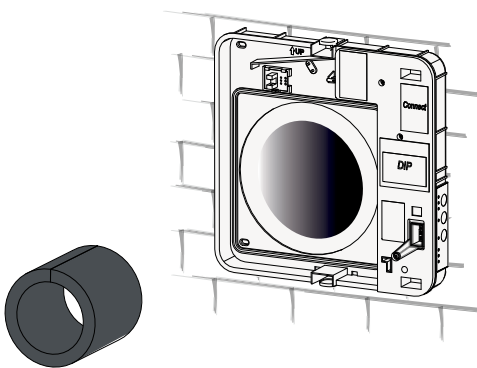

4 - Clean filters, core and silencer

Filters

The filters must be inspected at least every three months, where they either must be cleaned or replaced. The filters must be replaced with original filters from DUKA Ventilation at least once per year.

It may happen that the unit is installed in an environment where a shorter interval between maintenance is required. This could be, for example, in a dusty, dirty or humid environment. In installations where there is a risk of mould, the unit must be cleaned particularly thoroughly in order to remove dust and fungal spores completely. It may be necessary to use a special cleaning agent. Failure to do so terminates the warranty on the product.

Depending on how clogged or worn the filters are it is possible to vacuum and wash the filters a maximum of 4 times.

The filters must be dry before being placed on the core again.

The filter alarm is reset by holding down the heat recovery button on the side of the unit, until you hear a short biib, or in the app.

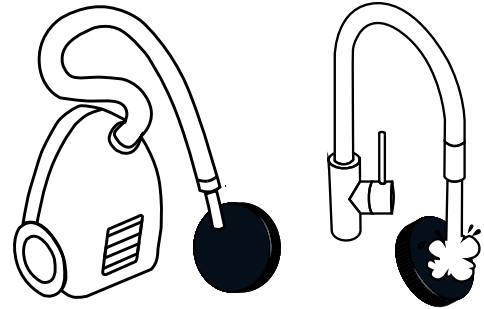

Core

Organic particles from the units surroundings can be deposited in the heat exchanger and fan making it important to clean these parts.

It can either be clean by vacuum or compressed air. When cleaning with compressed air fixate the core to make sure it will not rotate uncontrollably.

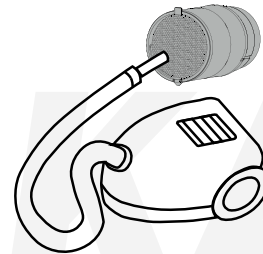

Silencer

The silencer must be cleaned either by vacuum or a gentle wash. Make sure the silencer is dry before installing it in the unit again.

Duct Cleaning

Clean the ducting with a damp cloth and a mild cleaning agent.

DUKA Clean can be used for this purpose.

Allow the ducting to dry completely before reinstalling the core, motor, and sound absorber.

Product	Product nr.	DB nr.	VVS nr.
Filterset Ø100 - 1 set of 2 pcs.	350045	1850327	358889810
DUKA Clean	420313	2275112	358889815

Remote control

After prolonged operation, it may be necessary to change the battery in the remote control.

Pull the battery drawer out of the remote control to change the battery and insert the new battery.

The battery is of type: CR 2025

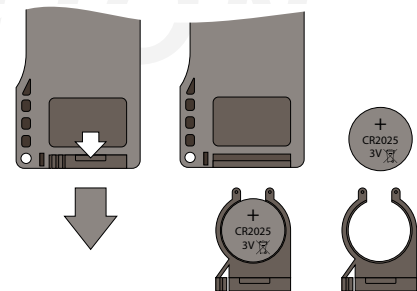

Troubleshooting

PROBLEM	POSSIBLE ERRORS	ERROR CORRECTION
The unit does not start	No power connection	<ul style="list-style-type: none"> • Make sure the unit is connected to a power source and the power is turned on. Alternatively make sure the unit is correctly connected.
	Fan is blocked or is encountering resistance	<ul style="list-style-type: none"> • Power of the unit • Check the engine for objects • Clean the fan. Restart the unit
Automatic circuit breaker switches on	Short circuit in the electrical network	<ul style="list-style-type: none"> • Power of the unit • Contact reseller
Low supply air temperature	The filters are clogged	Clean or replace the filters
	Heat exchanger is iced up	<ul style="list-style-type: none"> • Check the ceramic core for built up ice • Power off and wait for the ice to melt
Low air flow	Operating on level I	Choose a higher ventilation level
	Filter, fan or heat exchanger is clogged	<ul style="list-style-type: none"> • Clean or replace the filters • Clean fan and heat exchanger
High sound level or vibrations	Fan is dirty	Clean fan
	Lose screws	Tighten up screws
Filter alarm indicator still flashes after filter cleaning / replacement	The filter alarm has not been reset after maintenance.	Hold down heat recovery button on the side of the unit until you hear a bib, or reset it in the app. for more info, check "Maintenance"
The units is operating on highest level, all speed level indicators are flashing and the unit is not reacting to external signals	The humidity sensor is on and activated	<ul style="list-style-type: none"> • Power of the unit and change or deactivate the humidity sensor. See section "Settings"
The front diode is flashing and the fan goes out	The front cover is not correctly installed	<ul style="list-style-type: none"> • Install the front cover correctly and start the unit

VENTILATION

DUKA

dukaventilation.dk

VENTILATION